

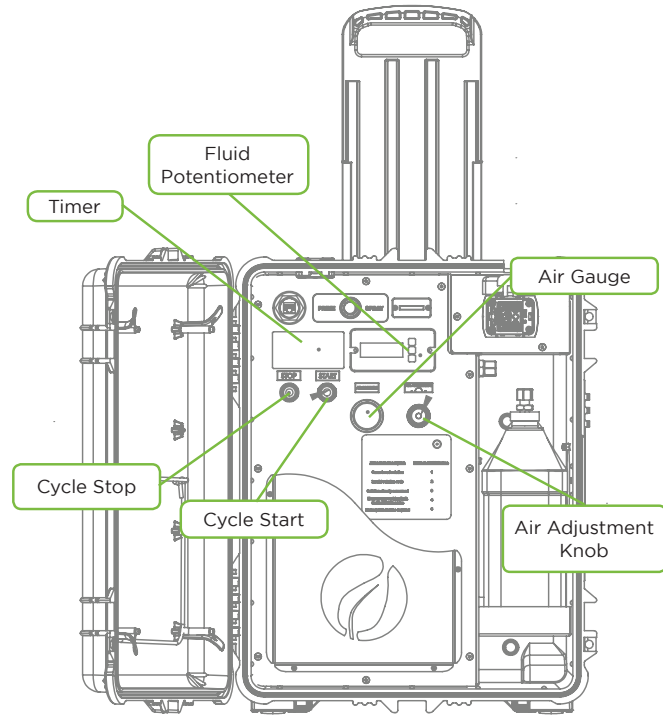

SELECT
STERAMIST[®]
 SURFACE UNIT



FEATURE	HHA-102-02
Voltage	110/120V AC, 5A
Disinfection/Decontamination Technology	ionized Hydrogen Peroxide (iHP™)
Number of iHP™ spray ports	1
Dimensions	0.64 m Length x 0.56 m Width x 0.38 m Depth (approximately 25" x 22" x 15")
Weight	Approximately 23 kg (49 lbs.) Applicator approximately 8 lbs.
Particle Size	0.05-3 Microns
Broad Spectrum Kill	Yes
Safe for Sensitive Equipment	Yes
Flow Rate	8-50 ml per minute
Applicator Compatibility	SteraMist® Handheld Applicator, SteraMist® 90 Degree Applicator
Treatment Method	Small Timed Chamber Custom Fogger and Manual, Direct Application onto Surfaces
Dose Application	Varied
Application Time	Varied
Dwell Time	7-15 minutes
Warranty (parts & labor)	One (1) year (voided if seal is broken). Extended Warranty Available.